

Performance Measures

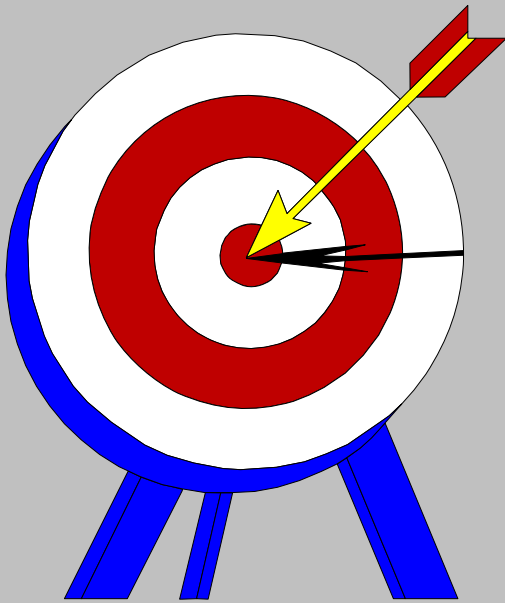

Objectives:

Know what performance measures are.

Know why performance measures are used.

Identify inputs, activities, outputs, and outcomes.

Write a good outcome measure.

Identify data sources for outcome measures.

What are performance measures ?



Performance Measures



tells us about
our
products,
services & the
processes that
produce
them.

But most of all...

Performance measures reflect the degree to which programs and services deliver desired results.

**What can performance
measures tell us about
a program?**



They let us know:

How well we are doing;

If we are meeting our goals;

If our customers are satisfied;

What information is necessary
to make decisions;

If & where improvements are
necessary.



THE VALUE OF A
PERFORMANCE
MEASURE
COMES FROM ITS
ABILITY TO



IMPROVE
PERFORMANCE,

NOT SIMPLY
MEASURE IT.

**Why do we use
Performance
Measures?**



Accountability

...is only possible when performance is measured against specific, limited, clearly defined targets.



Accountability is not about financial matters it is about getting to good outcomes.

For example: 95 percent of the individuals that completed job training were hired in a job for which they were trained.

*Ultimately, we use performance measures
to see if programs really make a difference
in the lives of people we serve.*



Hint – this is a long range outcome also known as your goal.

Performance Measurement 411



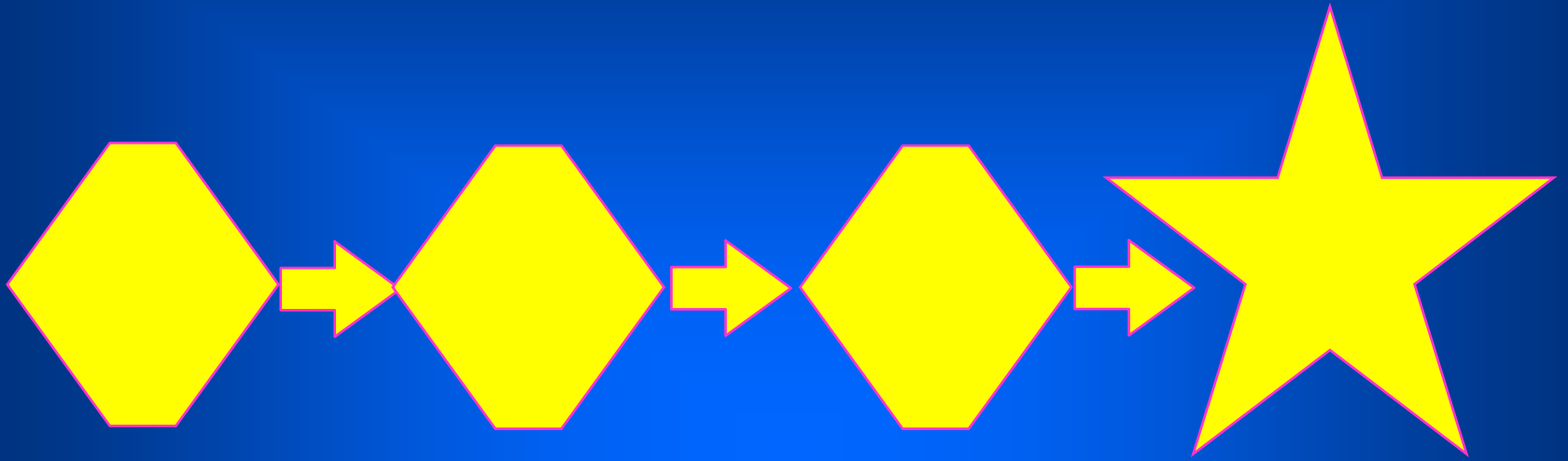

Drawing a Picture

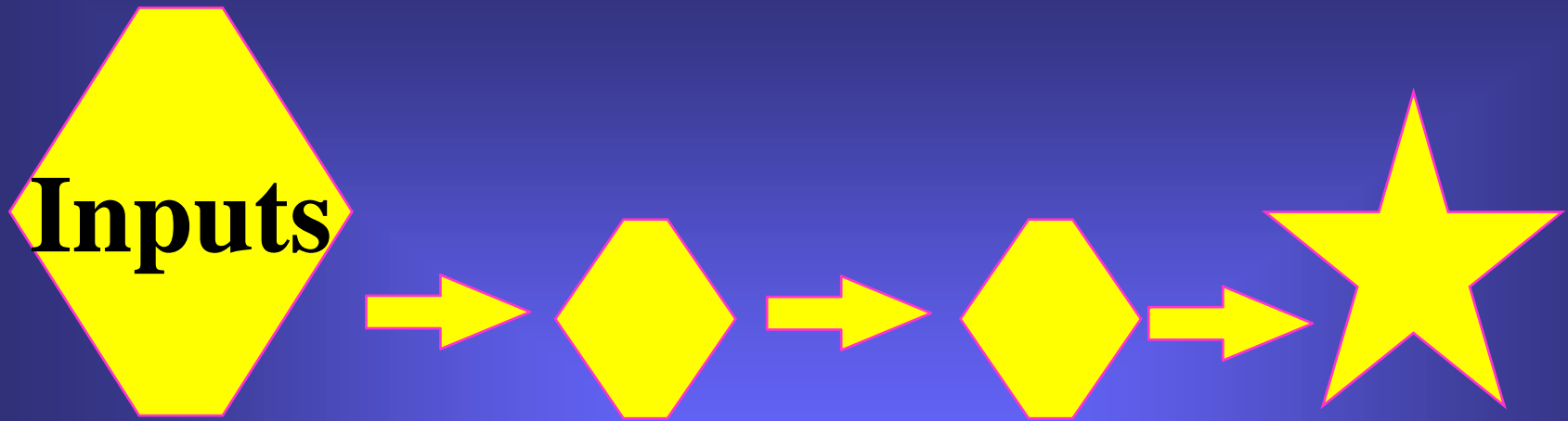

- Resources that an agency consumes to produce services.

INPUTS

- **Employees**
- **Employee hours worked**
- **Training packets**
- **Group sessions**

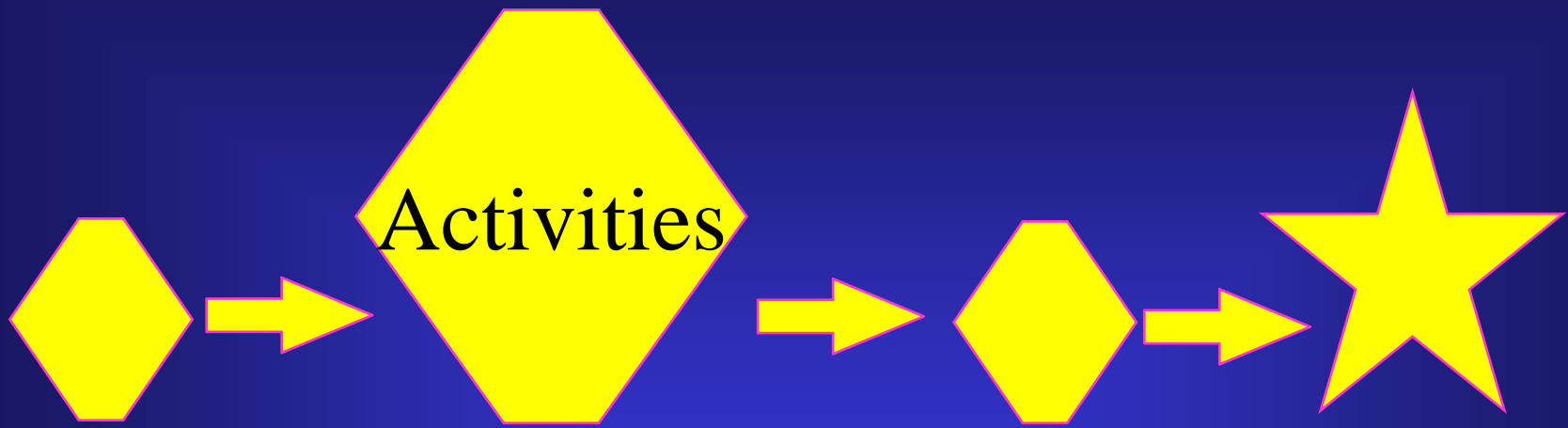

What the program does with its inputs to fulfill its mission.

ACTIVITIES

- **Teaching**
- **Conducting groups**
- **Hosting a special event**
- **Handing out materials**

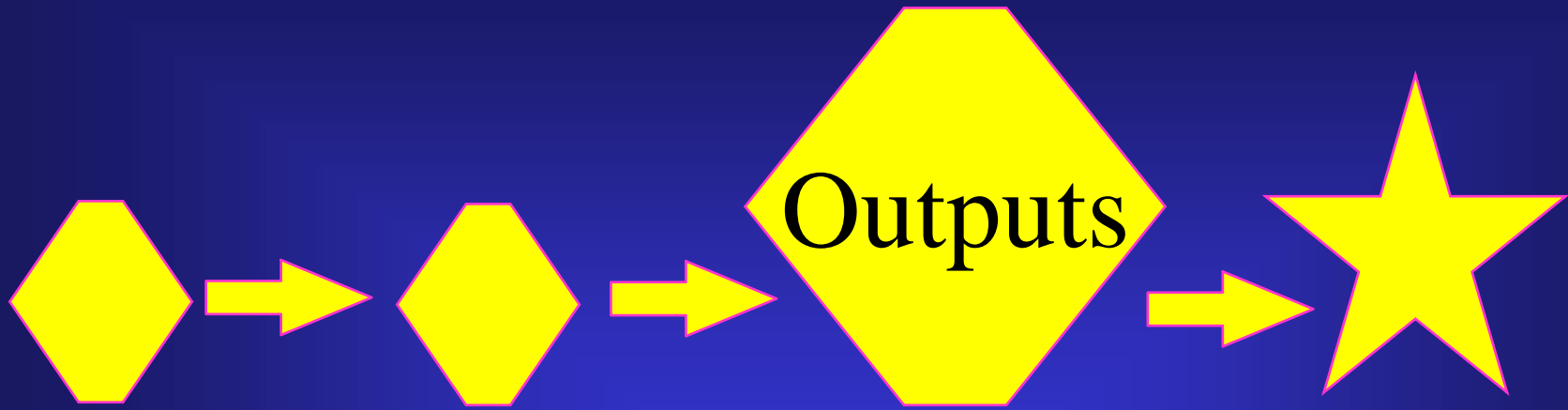

**Services produced
by the program.**

OUTPUTS

of parents completing classes

of children at an event

of people receiving materials

of children completing a program

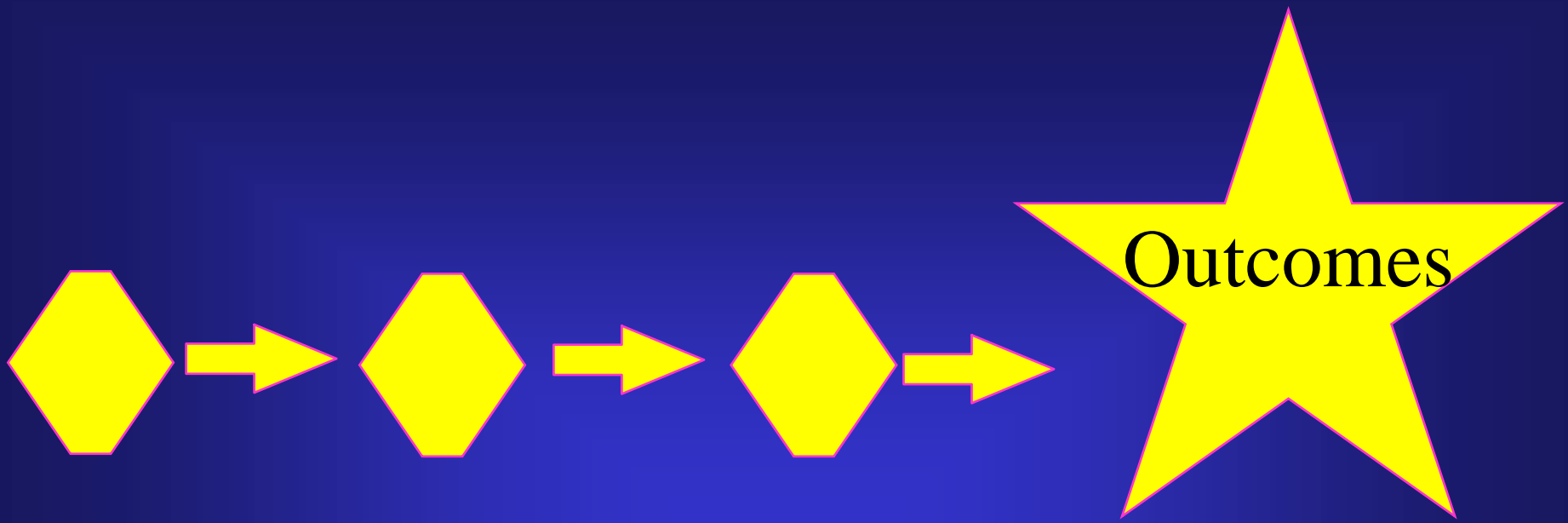

Indicates the extent to which an activity or program meets its goals.

OUTCOMES

% of children served showing improvement in functioning as measured by pre-& post-test

% of parents served who increase their active participation in your program

Inputs/Activities/Outputs/Outcomes

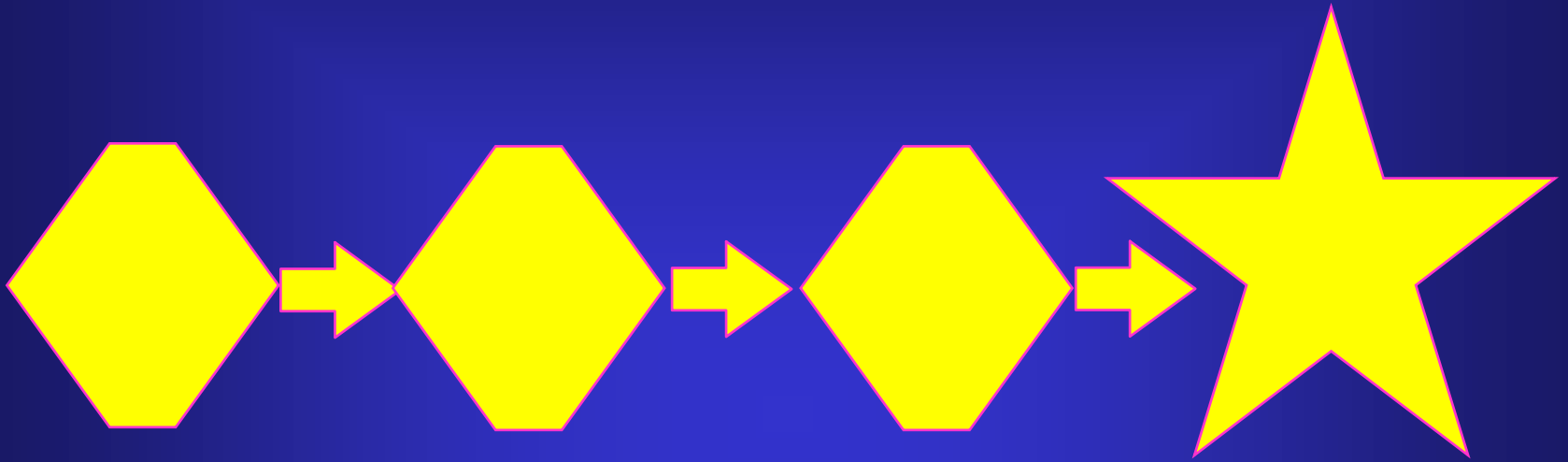

**The Big Picture
Outcome Model**

Outcome vs. Output

Output Measure: number of children who attended your program.

Outcome Measure: percentage of children served who show increased life skills.

Activity





Levels of Outcome

In many cases, there is not just one desired outcome for participants, but a series, each contributing to another benefit or change that leads closer to the ultimate outcome the program hopes to achieve for participants.

Initial Outcomes

- The first changes or benefits participants experience.
- The outcomes most closely associated to program outputs.
- Often these are changes in knowledge, skills & attitudes.

? Are these changes ends in themselves?

? Why or why not?

Intermediate Outcomes

- **Link a program's initial outcomes to long-term outcomes.**
- **These are usually changes in behavior resulting from increased knowledge, attitudes, or skills.**

Long-range Outcomes

- The ultimate outcomes a program desires for its participants.
- Represent meaningful changes for participants (condition or status).
- Reflect the expectation that an individual will continue to progress in growth and development.

**What you measure is what you get--
so, what do you want?**



To be of value to your organization,
each measure should be directly related
to the result that is desired for the
program or activity.

Therefore, the all important first step
is considering and understanding
what **GOAL** is truly desired.



Sources of Ideas for Outcomes

*** Program documents**

*** Program Staff**

*** Key volunteers**

*** Program Participants**

*** Participants' parents or caregivers**

*** Programs with missions, services,
and participants similar to yours**

Outcome measures can be directed towards:

Effectiveness

Efficiency

Quality

Timeliness

Productivity

Safety



How do we write an effective measure?

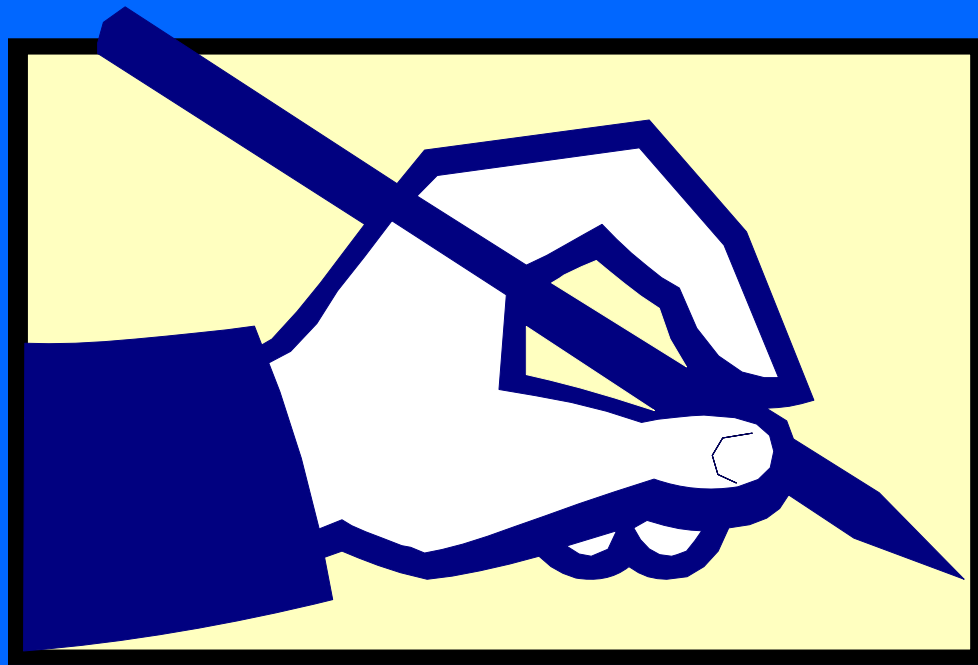

Performance measures should be...



The image displays the acronym 'SMART' in large, bold, 3D-style letters. Each letter is a different color and has a corresponding colored bar below it. The letters are: S (pink), M (red), A (yellow), R (blue), and T (purple). The bars are: a pink bar under the S, a red bar under the first M, an orange bar under the second M, a yellow bar under the A, a green bar under the first R, a blue bar under the second R, and a purple bar under the T. The letters and bars are set against a white background with a subtle shadow effect.

Specific- Measurable- Attainable- Results-oriented- Time-bound

Specific

Specific enough to give clear direction, and easily understood by your funder, program staff and the public.

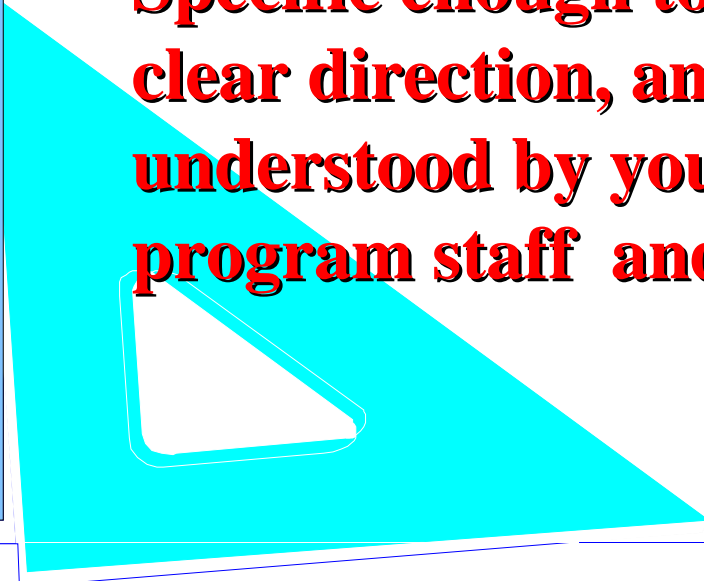
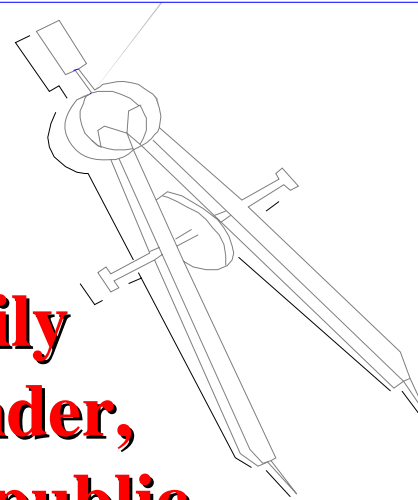

Measurable

Quantifiable;
most often takes the form
of a fraction:

(successful cases)

(all cases)

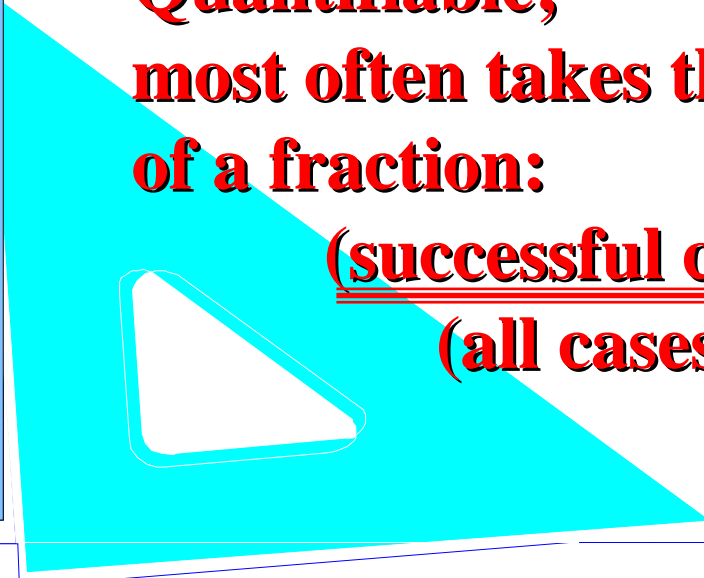
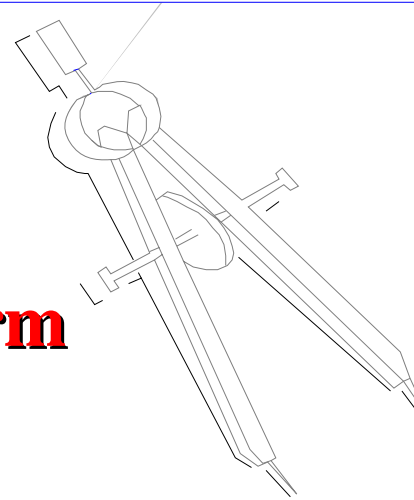

Attainable

Targets should be realistic (for example, reduce- not eliminate).

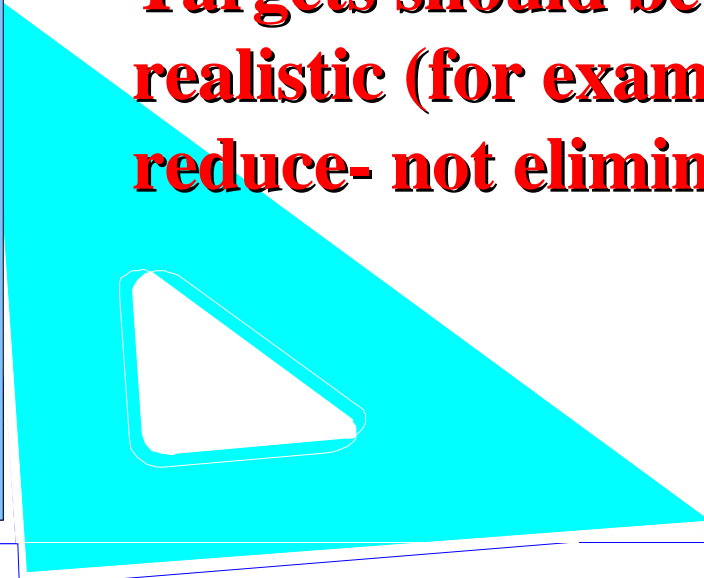
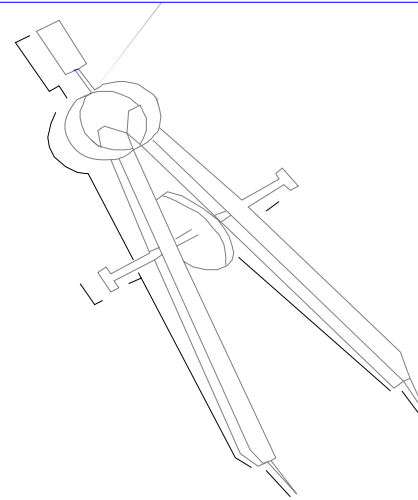

Results-oriented

**Focus on desired
results, not on methods
to achieve them.**

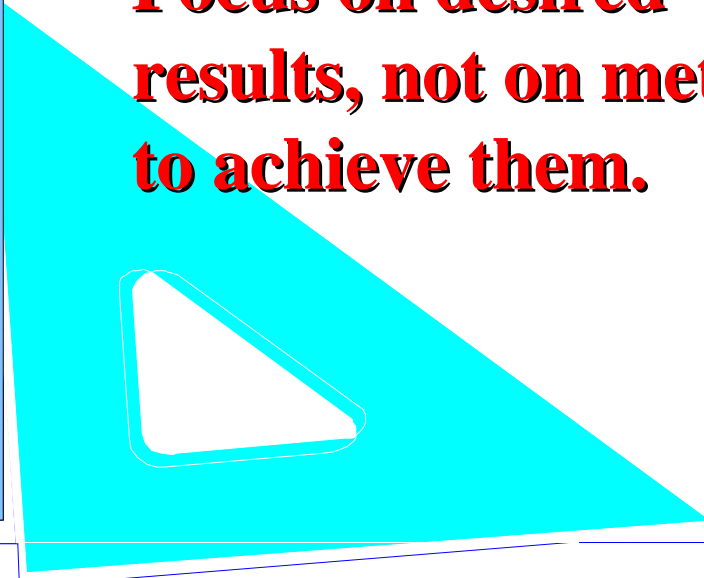
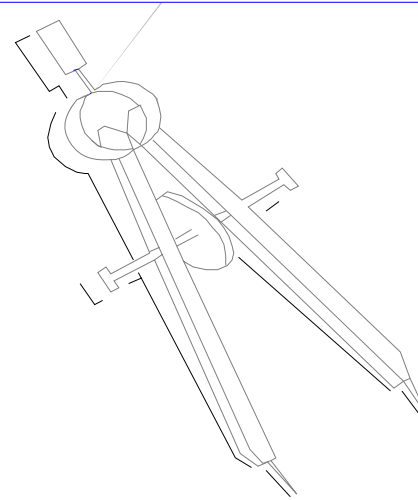

Time-bound

**Completion date should
be reasonable
(within the time
frame of the contract).**

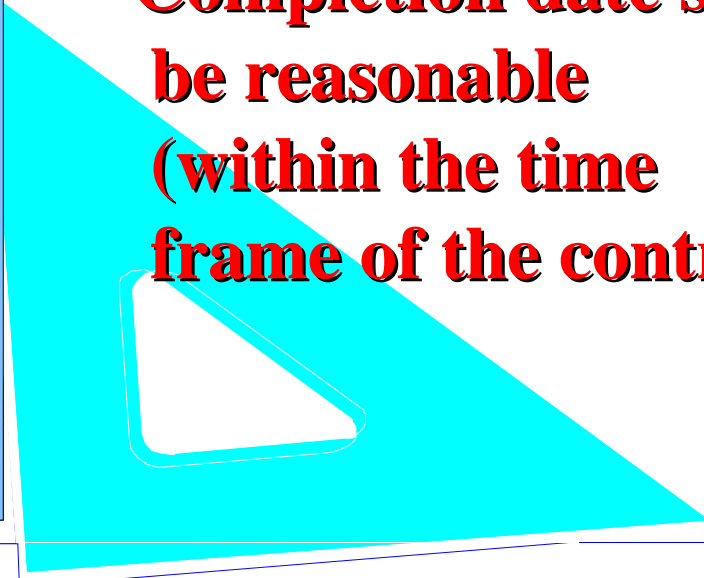
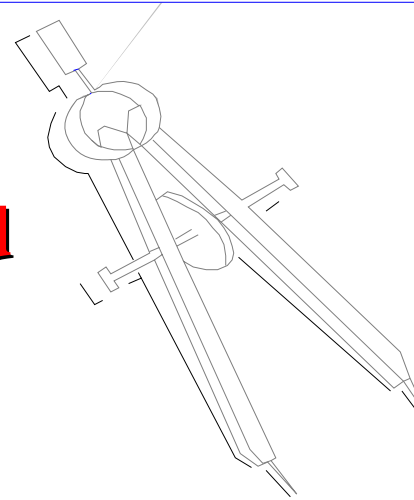

Helpful Hint #1

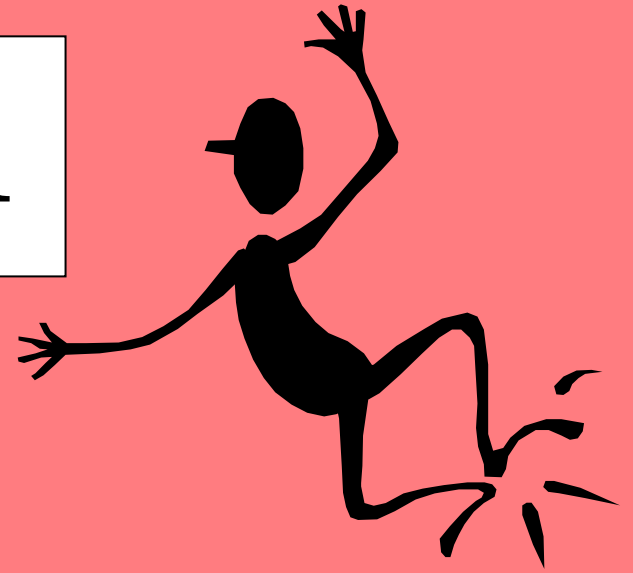

Programs may only be able to measure initial outcomes.

If participants are anonymous, programs cannot follow up for intermediate and long-term outcomes.

For example: homeless shelters, hotlines.

Longer term outcomes can be difficult or impossible to measure due to anonymity.

Helpful Hint #2



Programs may have more than one outcome.

The is no “right” number of outcomes for a program.

For example...

Helpful Hint #3



Measures should report on
the largest portion of money spent.

?.

For example...

Activity



HERE'S A DRAFT OF MY
NEW OBJECTIVES. I
TRIED TO MAKE THEM
ACHIEVABLE.

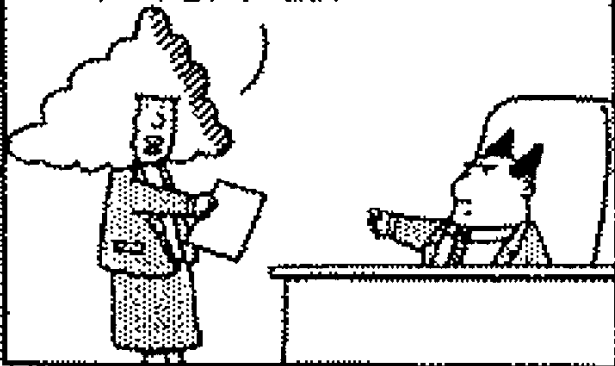

STAYING © 1998 United Feature Syndicate, Inc. (R) VCS
SADAM'S E-mail: SCOTTADAM@AOL.COM

"NO MATTER HOW STUPID
MY CO-WORKERS ARE, I
WILL NOT PUNCH A HOLE
IN ANYONE'S TORSO, RIP
OUT A VITAL ORGAN AND
KEEP IT IN MY CUBICLE
AS A WARNING
TO OTHERS."



STAYING © 1998 United Feature Syndicate, Inc. (R) VCS

I HOPE
SHE GETS
THOSE
OBJECTIVES
APPROVED.

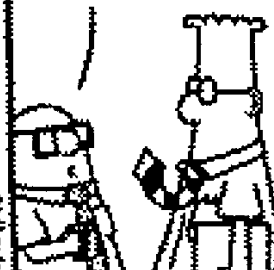

YES! IT'S
MEASURABLE!

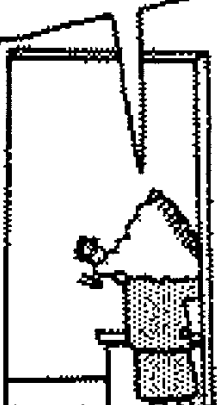

Key Issues in Data Collection

When will it be collected?

Who is a participant?

Who will collect the data?

What will it cost to collect?

How long will it take to generate?



What if I have questions?

Michelle Reddinger
Director, Prevention Program and
Technical Assistance
Florida Office of Drug Control
Office of Governor Charlie Crist
The Capitol, Suite 2105
Tallahassee, FL 32399-0001
Phone: (850) 922-6910
Fax:(850) 922-9936
http://www.flgov.com/drug_control/



Your Presenters

Kimberly Munt

Substance Abuse Program Office

1317 Winewood Blvd., Bldg. 6, Rm.323

Tallahassee, Fl. 32399-0700

PH: (850) 413-6674 or SC: 293-6674

FAX: (850) 413-6773 or SC: 293-6773

Senta Goudy

SPF SIG Coordinator

Florida Department of Children and Families

1317 Winewood Boulevard

Building 6, Room 321

Tallahassee, FL 32399-0700

Office: 850-413-6666

FAX: 850-413-6773

senta_goudy@dcf.state.fl.us